

Cruise Control (2ZR-FAE), CVT and Shift Indicator (2ZR-FAE), Engine Control (2ZR-FAE)

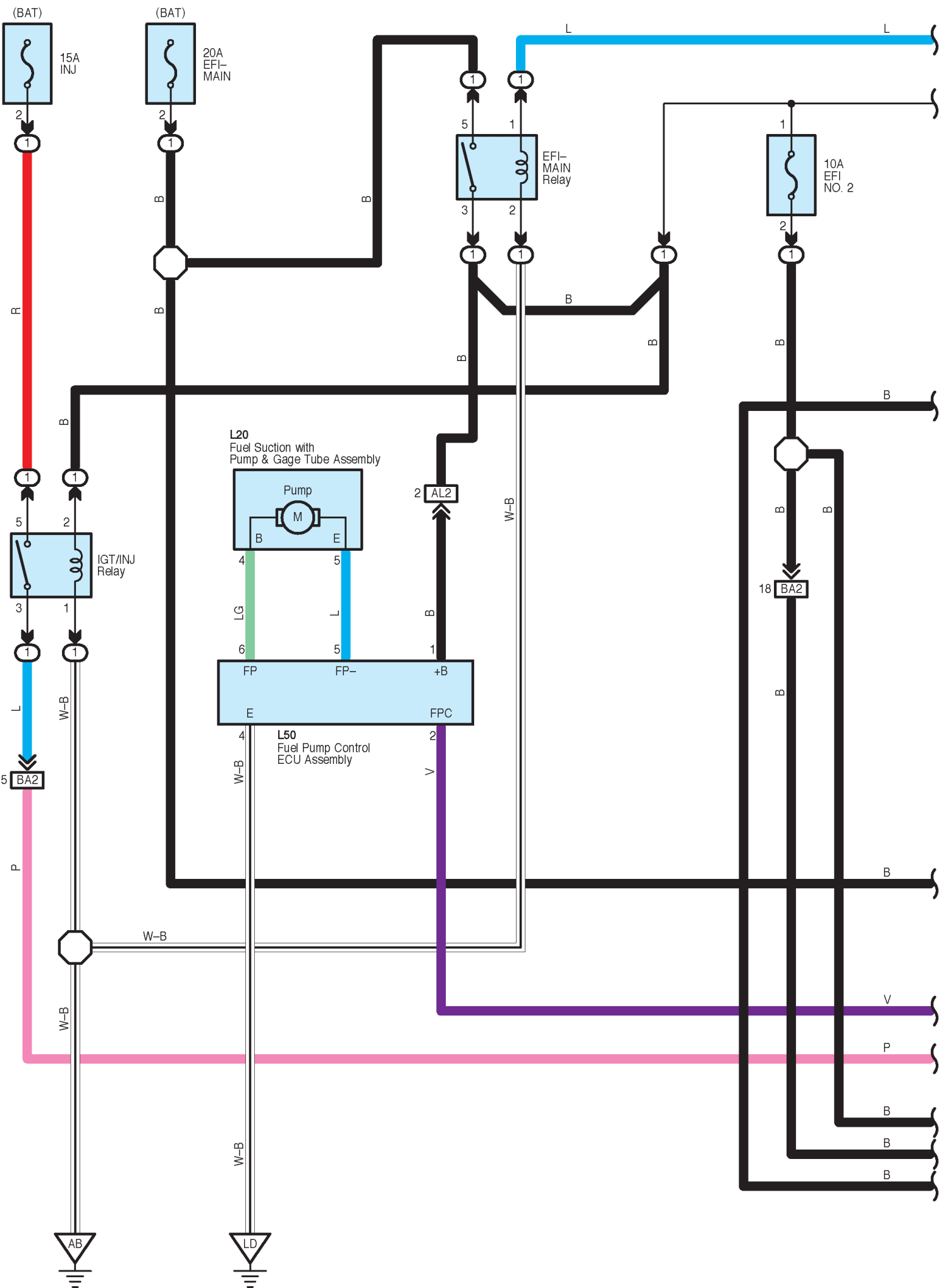

Cruise Control (2ZR-FAE), CVT and Shift Indicator (2ZR-FAE), Engine Control (2ZR-FAE)

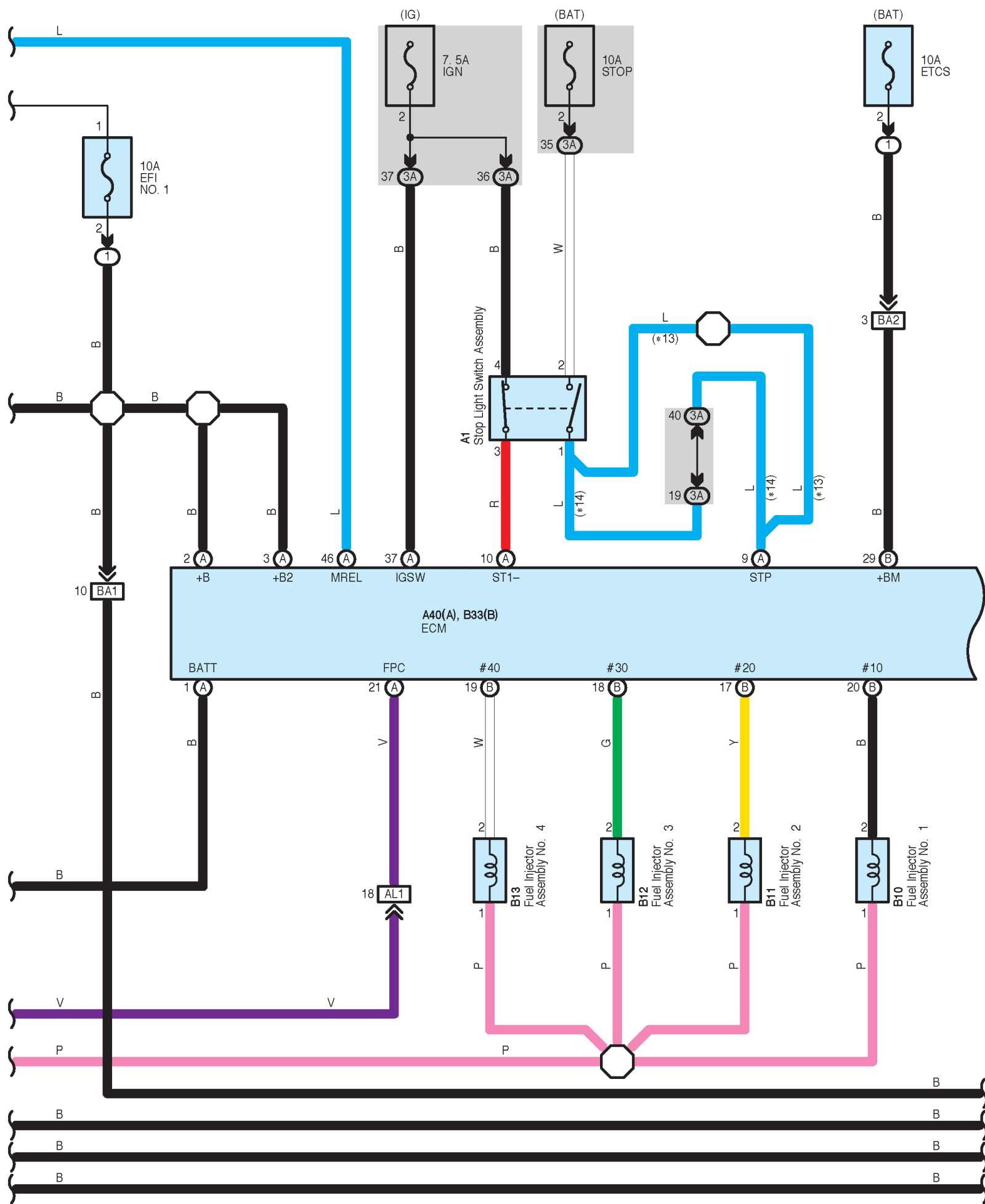

\*13 : w/ Dynamic Radar Cruise Control  
 \*14 : w/o Dynamic Radar Cruise Control

Cruise Control (2ZR-FAE), CVT and Shift Indicator (2ZR-FAE), Engine Control (2ZR-FAE)

\* 7 : w/ Smart Key System  
 \* 8 : w/o Smart Key System

**E25**  
 Transponder Key  
 ECU Assembly

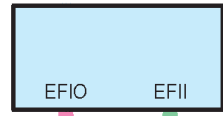

**E56**  
 ID Code Box

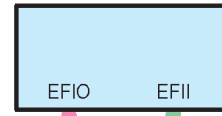

**B41**  
 Valve Event Angle  
 Control Shaft Monitor Sensor  
 (No. 1 Crank Position Sensor)



**B39**  
 E. F. I Vacuum  
 Sensor Assembly

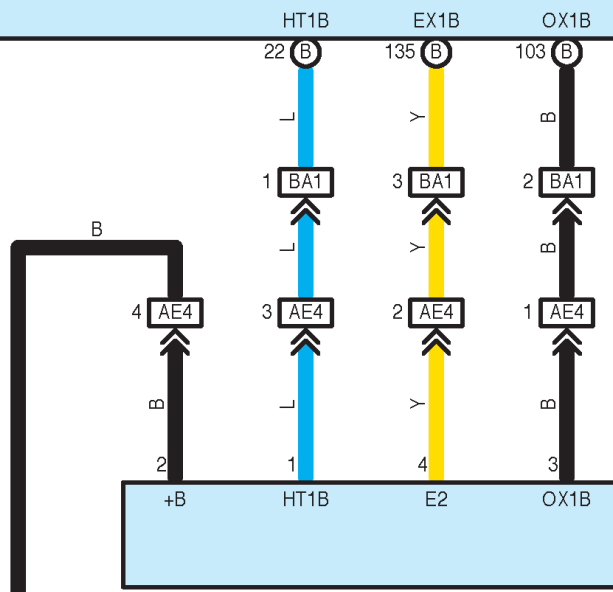
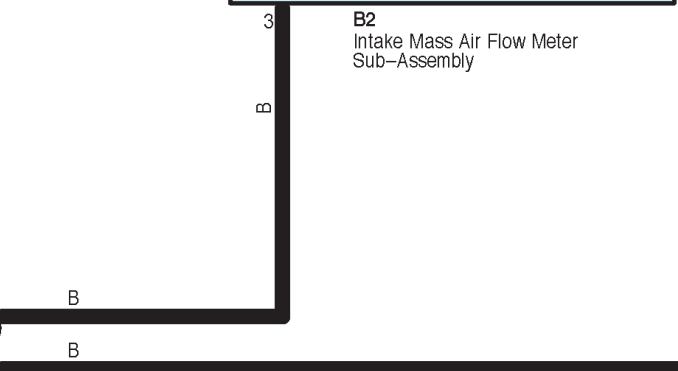
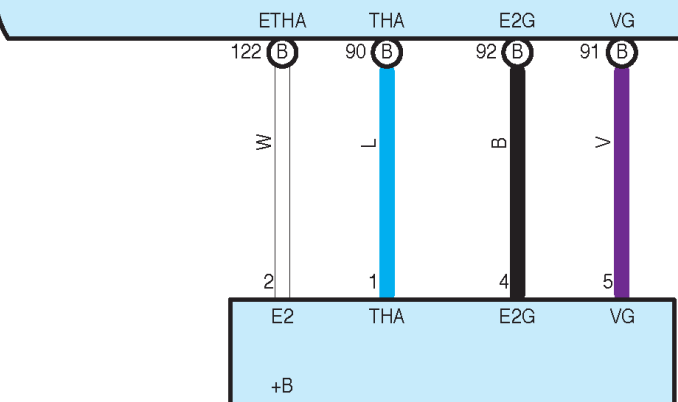
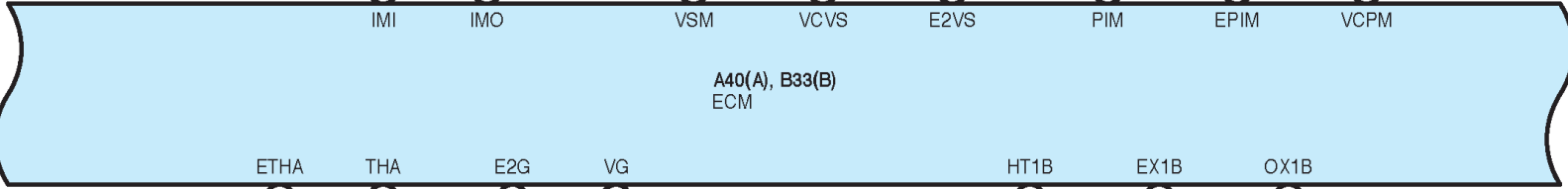
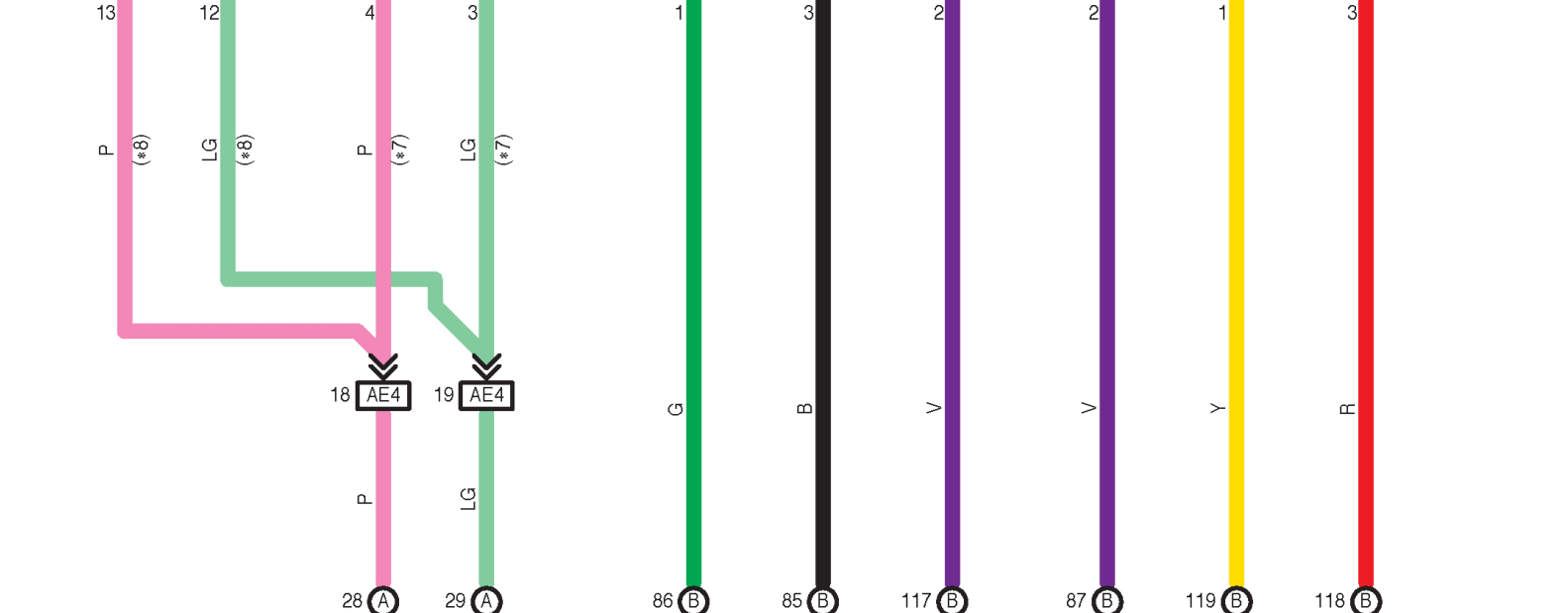
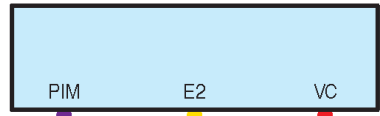



Cruise Control (2ZR-FAE), CVT and Shift Indicator (2ZR-FAE), Engine Control (2ZR-FAE)

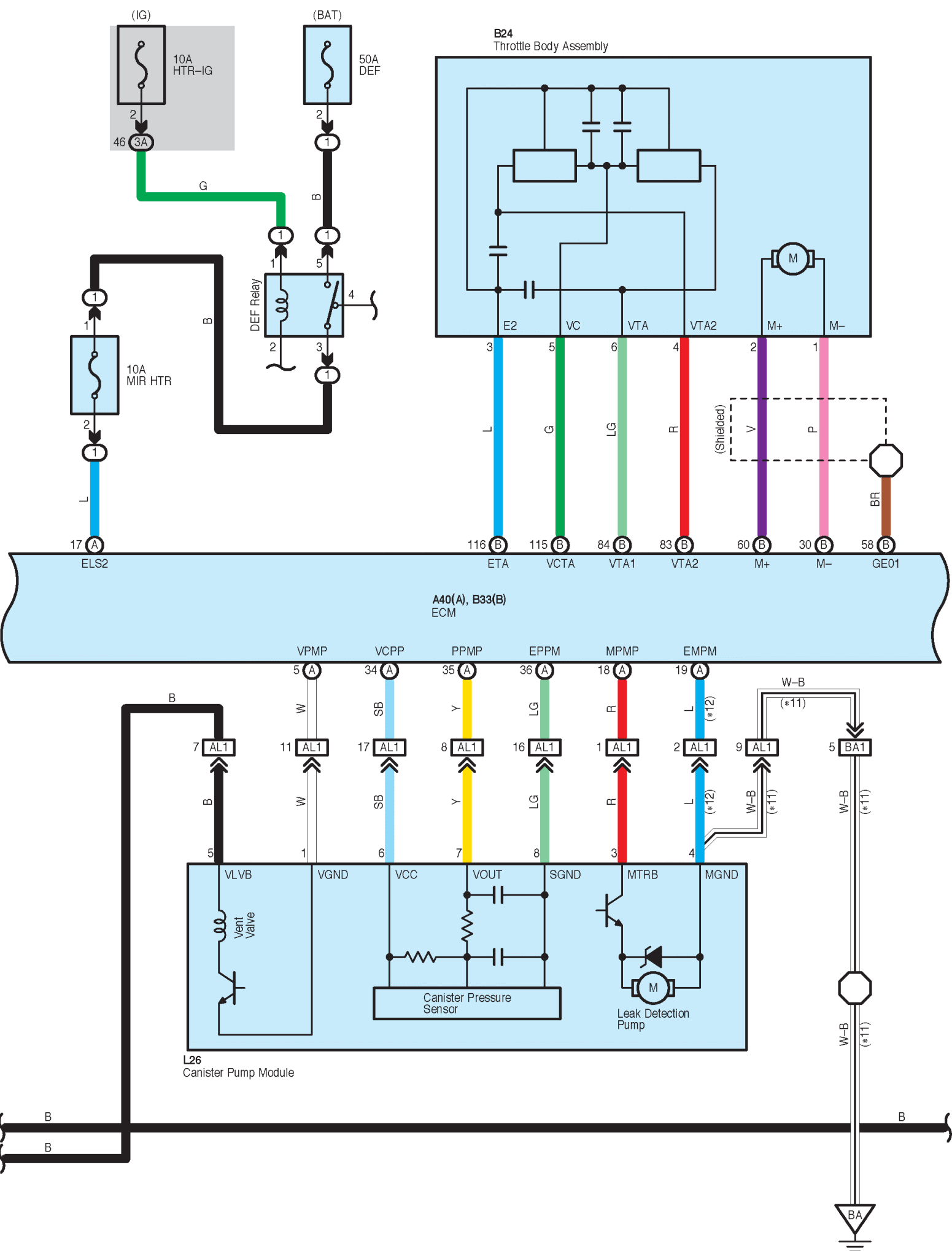

Cruise Control (2ZR-FAE), CVT and Shift Indicator (2ZR-FAE), Engine Control (2ZR-FAE)

- \* 6 : M/T
- \* 7 : w/ Smart Key System
- \* 8 : w/o Smart Key System
- \* 11 : Before Aug. 2016 Production
- \* 12 : From Aug. 2016 Production

A2  
Accelerator Pedal Sensor Assembly

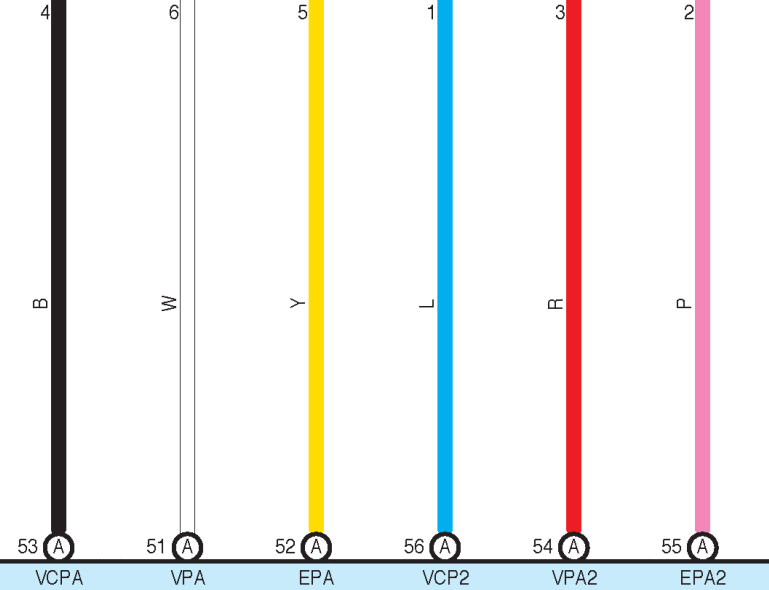
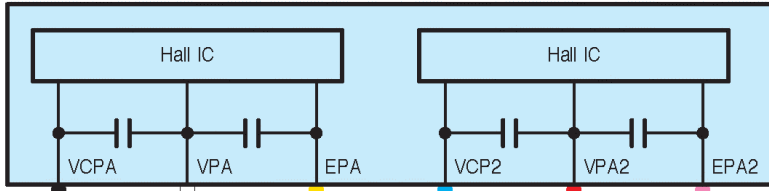

A40(A), B33(B)  
ECM

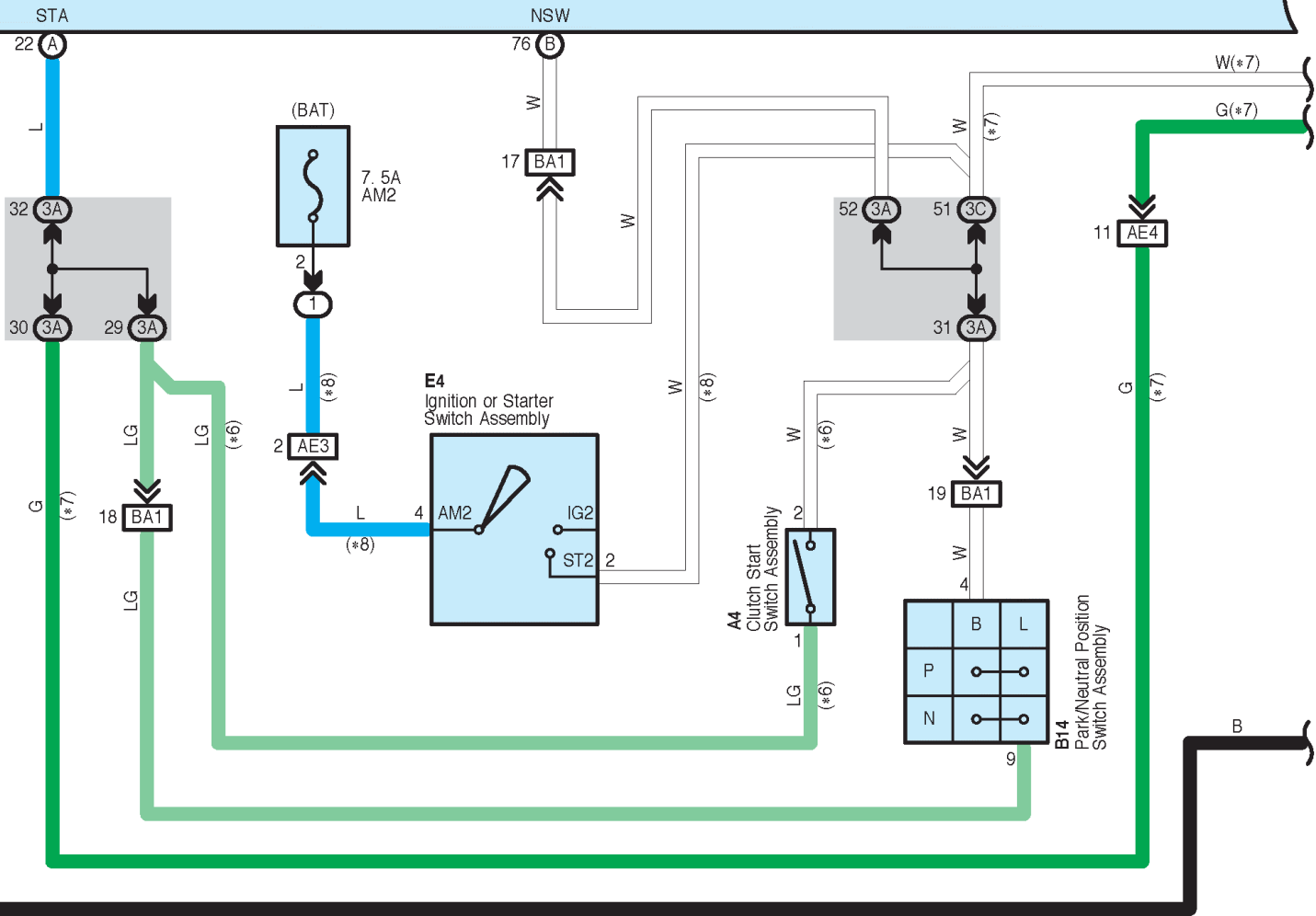

# Cruise Control (2ZR-FAE), CVT, and Shift Indicator (2ZR-FAE), Engine Control (2ZR-FAE)

- \* 1 : CVT
- \* 7 : w/ Smart Key System
- \*11 : Before Aug. 2016 Production
- \*12 : From Aug. 2016 Production

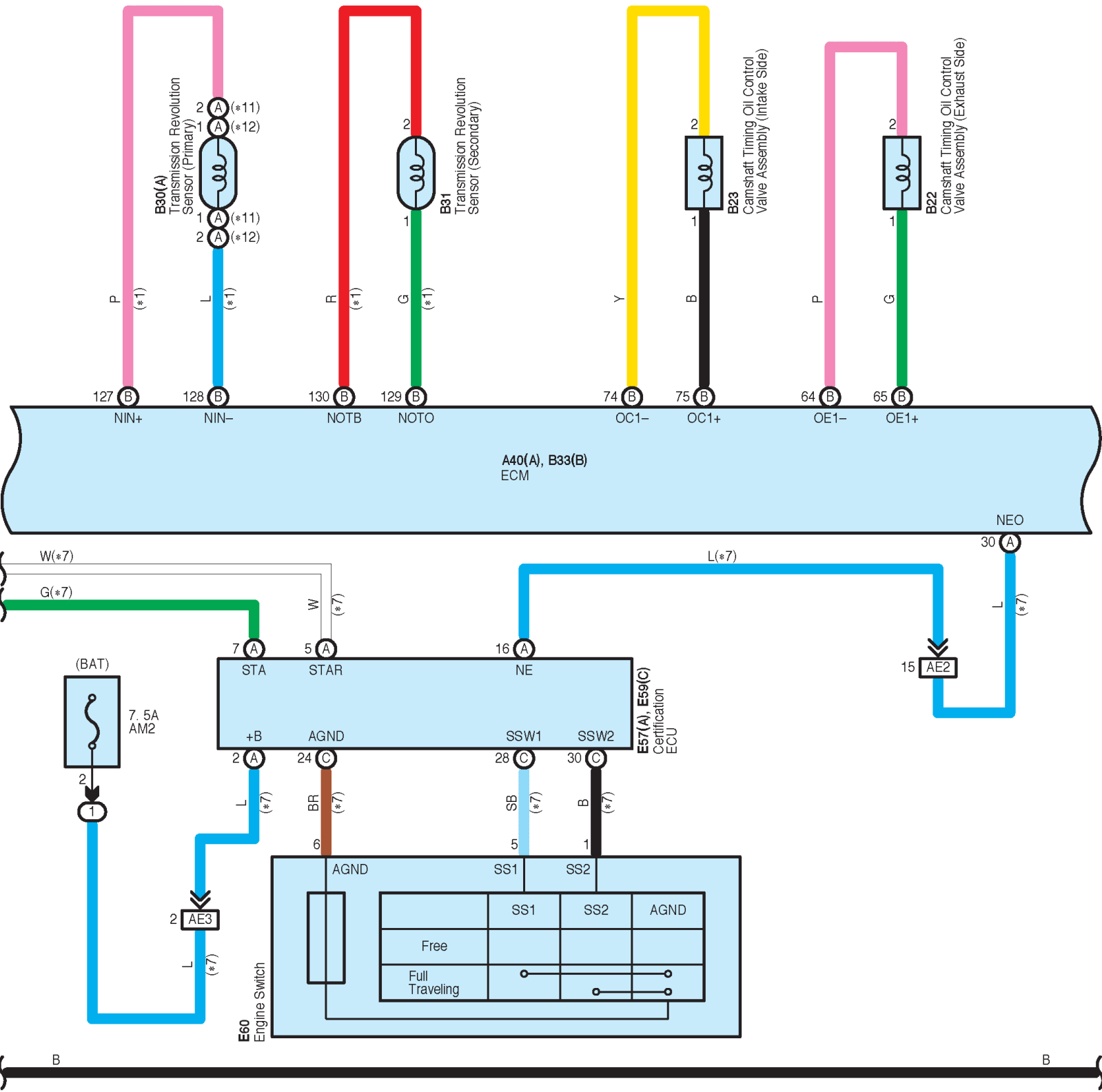

Cruise Control (2ZR-FAE), CVT and Shift Indicator (2ZR-FAE), Engine Control (2ZR-FAE)

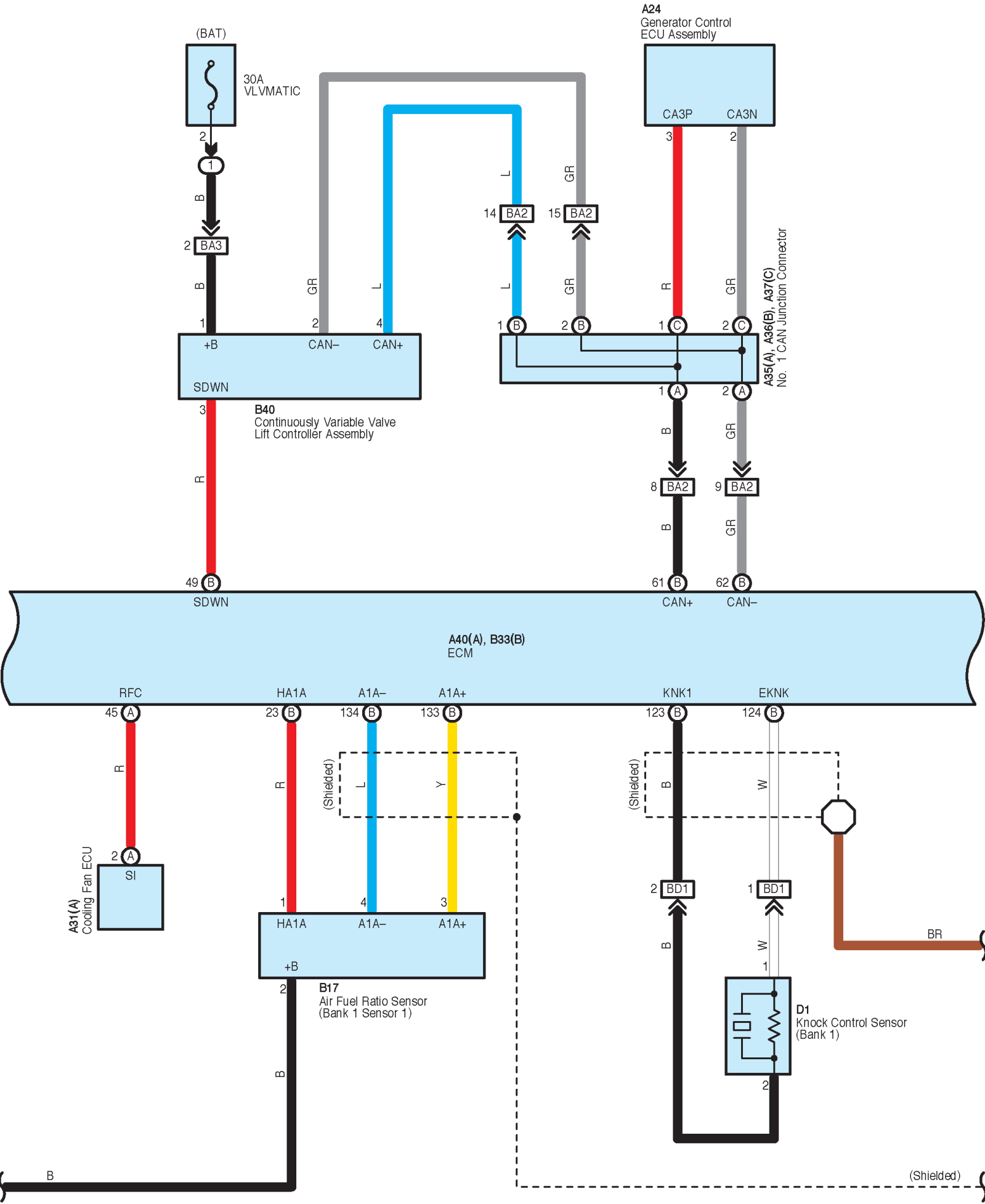



Cruise Control (2ZR-FAE), CVT and Shift Indicator (2ZR-FAE), Engine Control (2ZR-FAE)

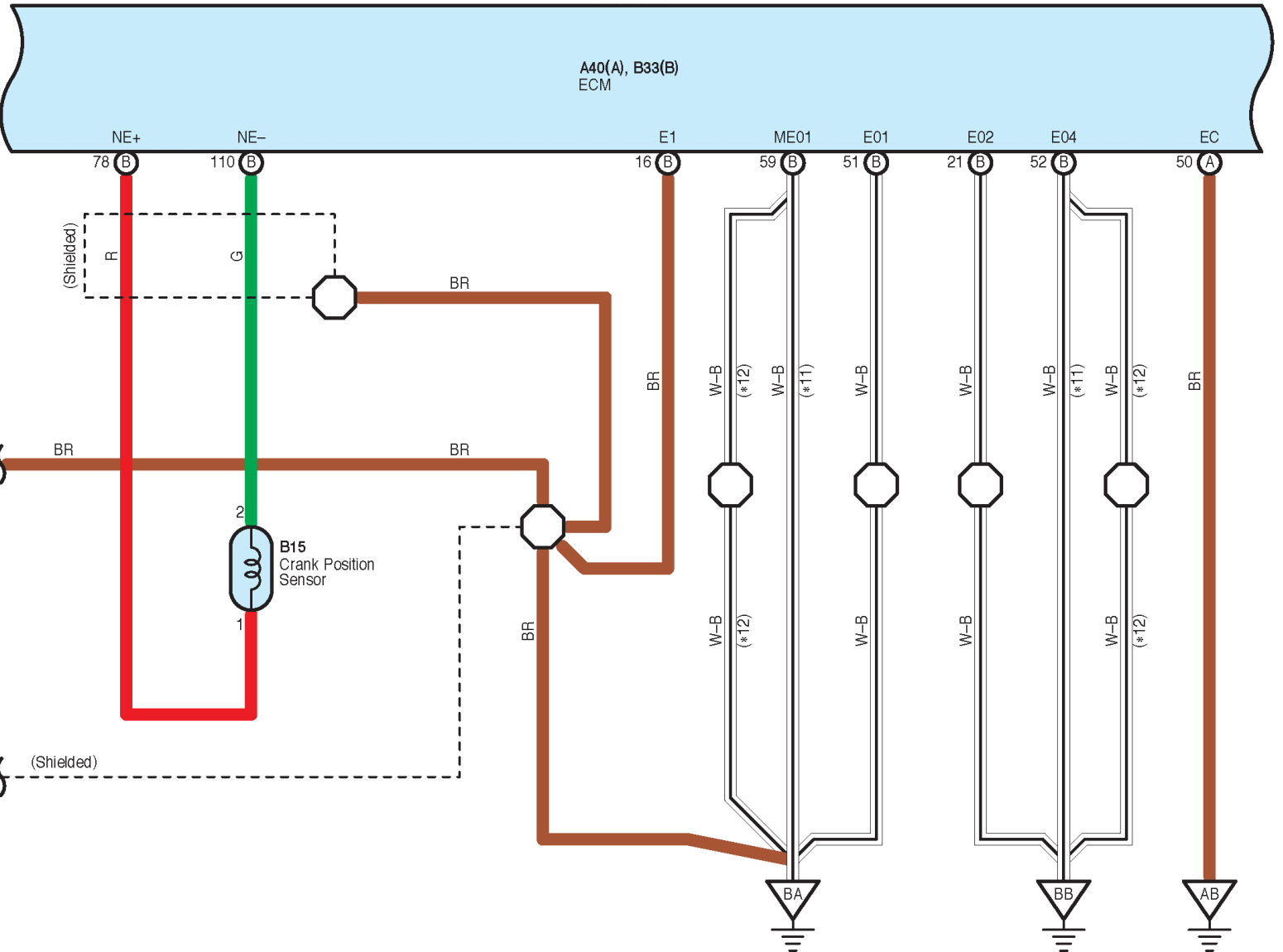
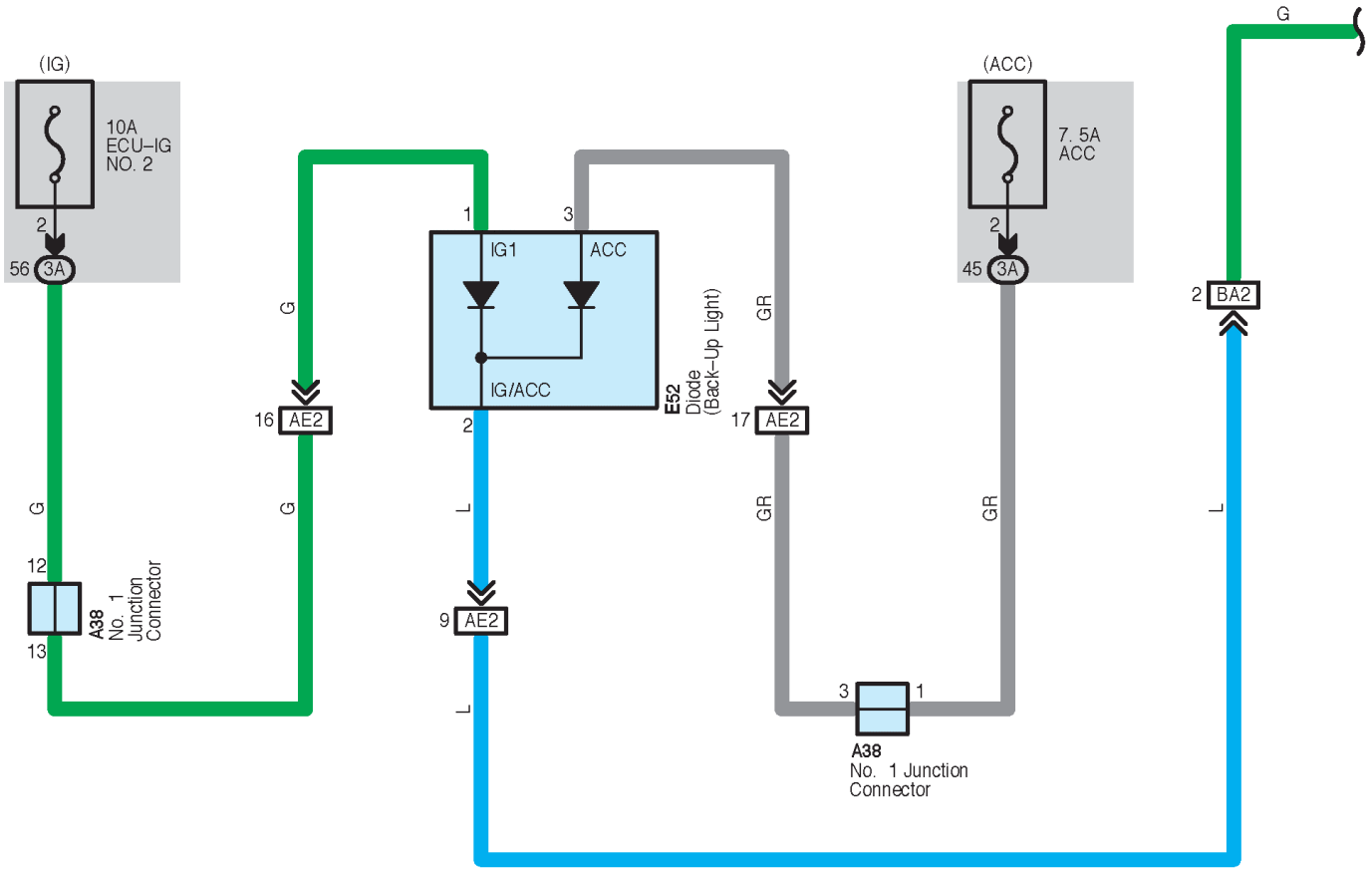

Cruise Control (2ZR-FAE), CVT and Shift Indicator (2ZR-FAE), Engine Control (2ZR-FAE)

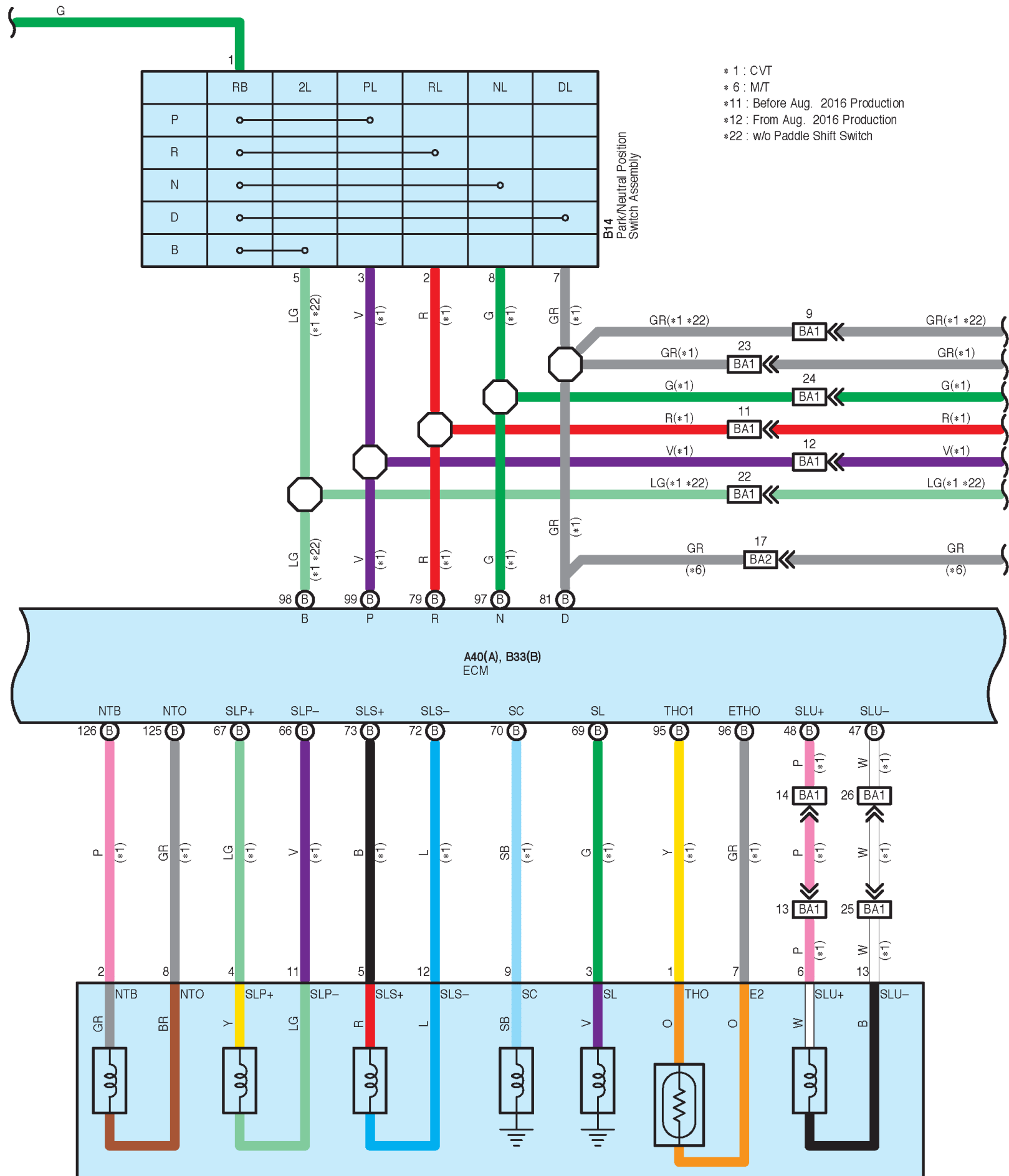

B18  
CVT Solenoid (Transmission Wire)

Cruise Control (2ZR-FAE), CVT and Shift Indicator (2ZR-FAE), Engine Control (2ZR-FAE)

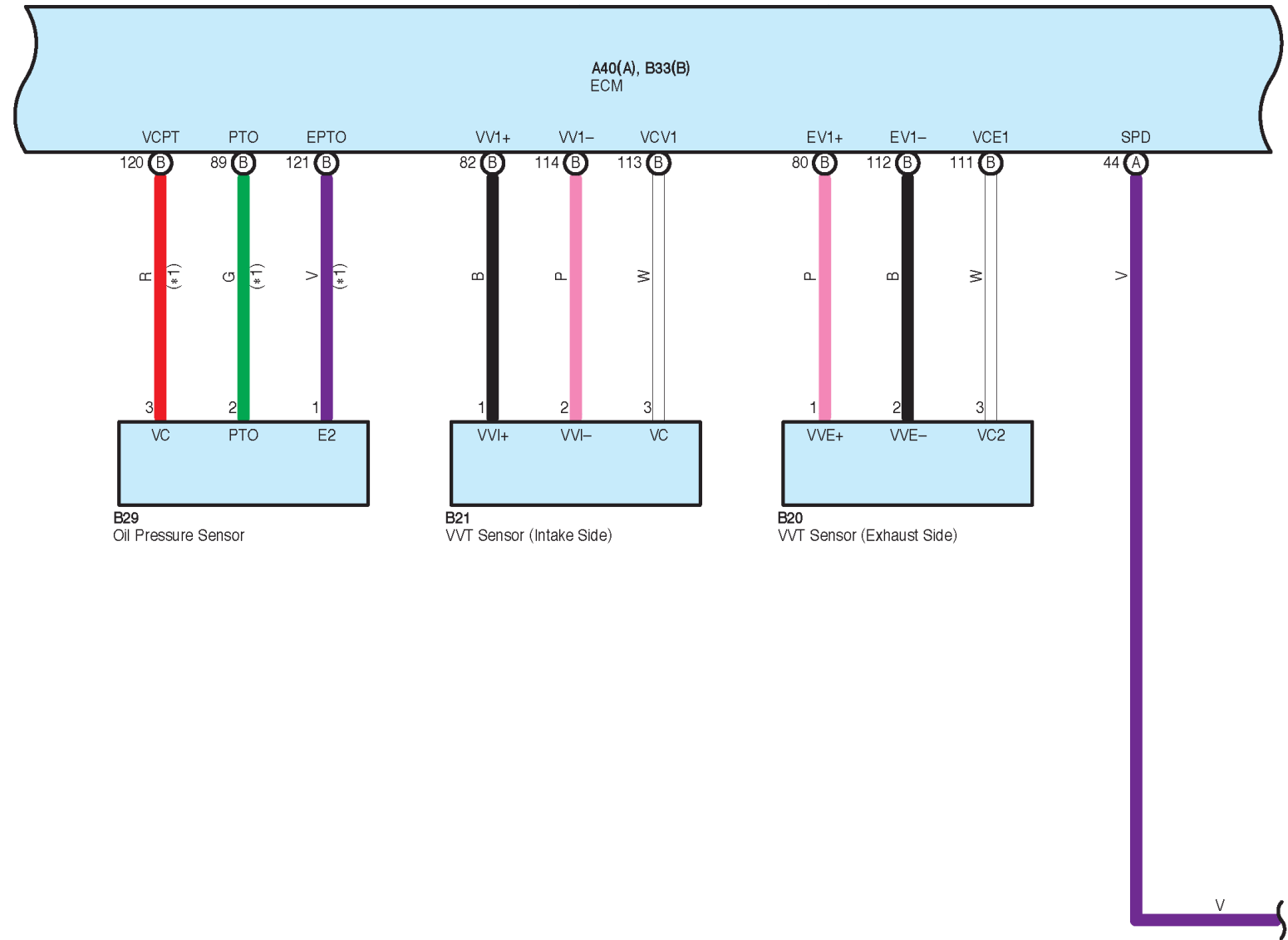
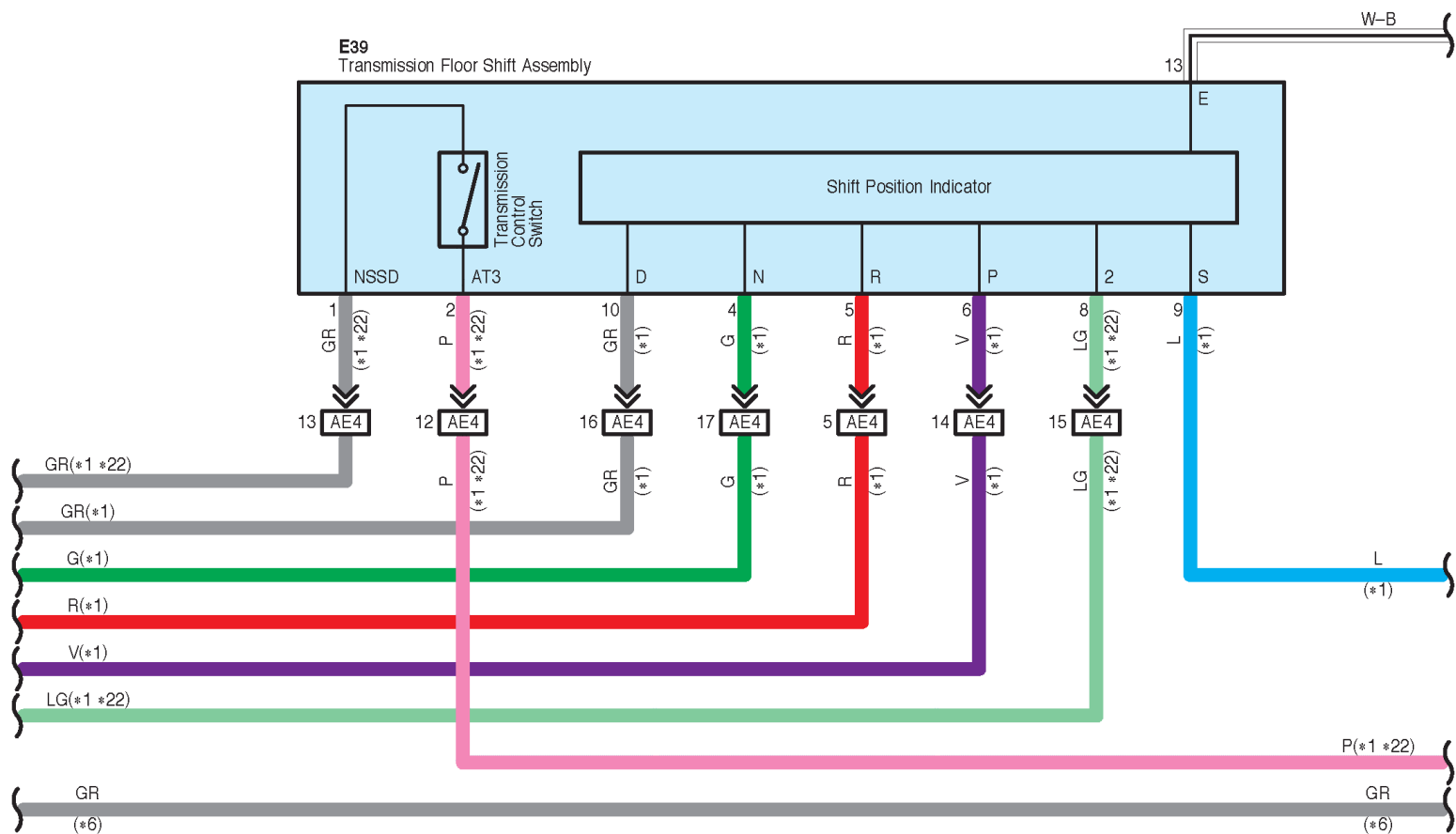

Cruise Control (2ZR-FAE), CVT and Shift Indicator (2ZR-FAE), Engine Control (2ZR-FAE)

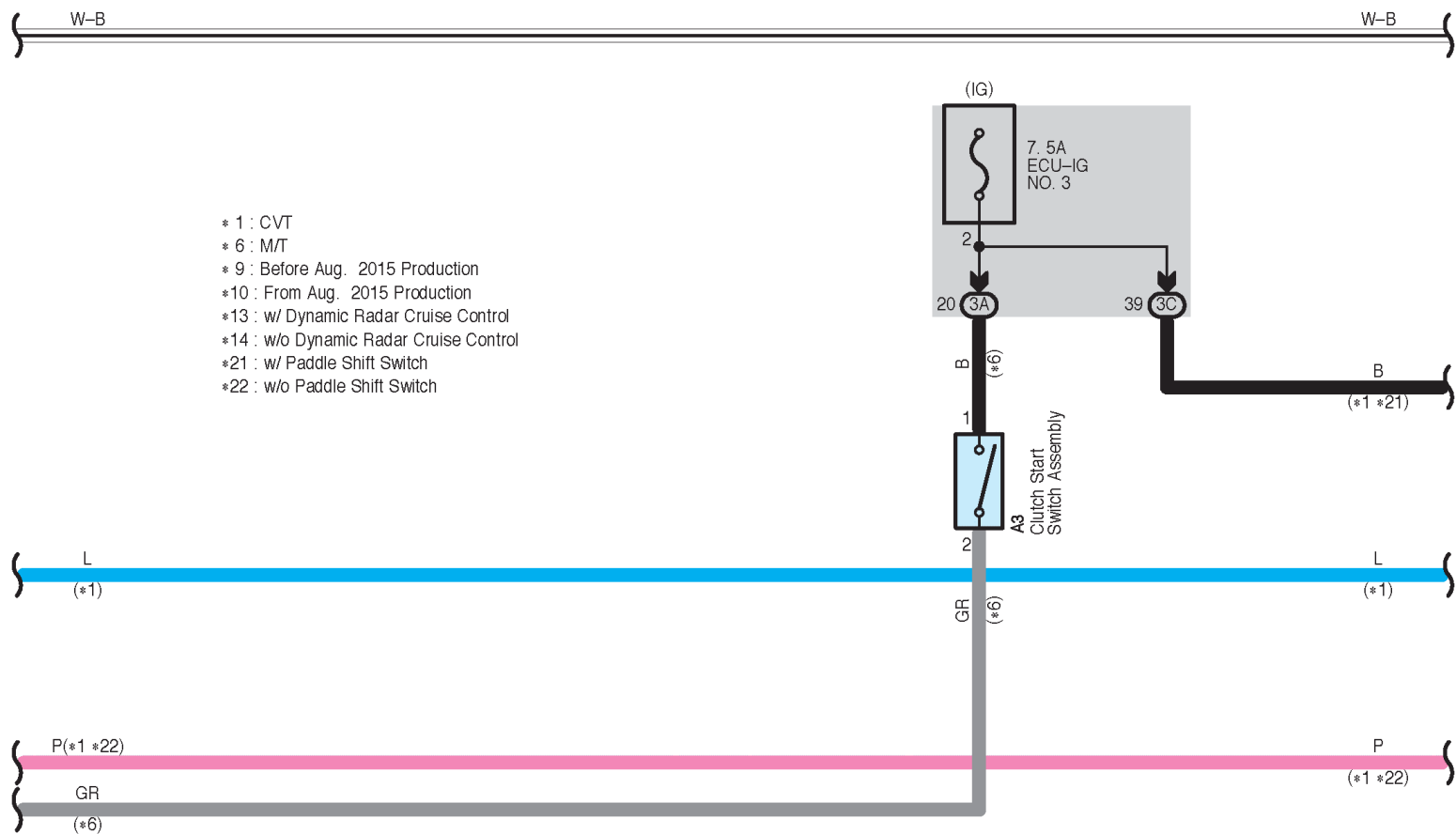

- \* 1 : CVT
- \* 6 : M/T
- \* 9 : Before Aug. 2015 Production
- \*10 : From Aug. 2015 Production
- \*13 : w/ Dynamic Radar Cruise Control
- \*14 : w/o Dynamic Radar Cruise Control
- \*21 : w/ Paddle Shift Switch
- \*22 : w/o Paddle Shift Switch

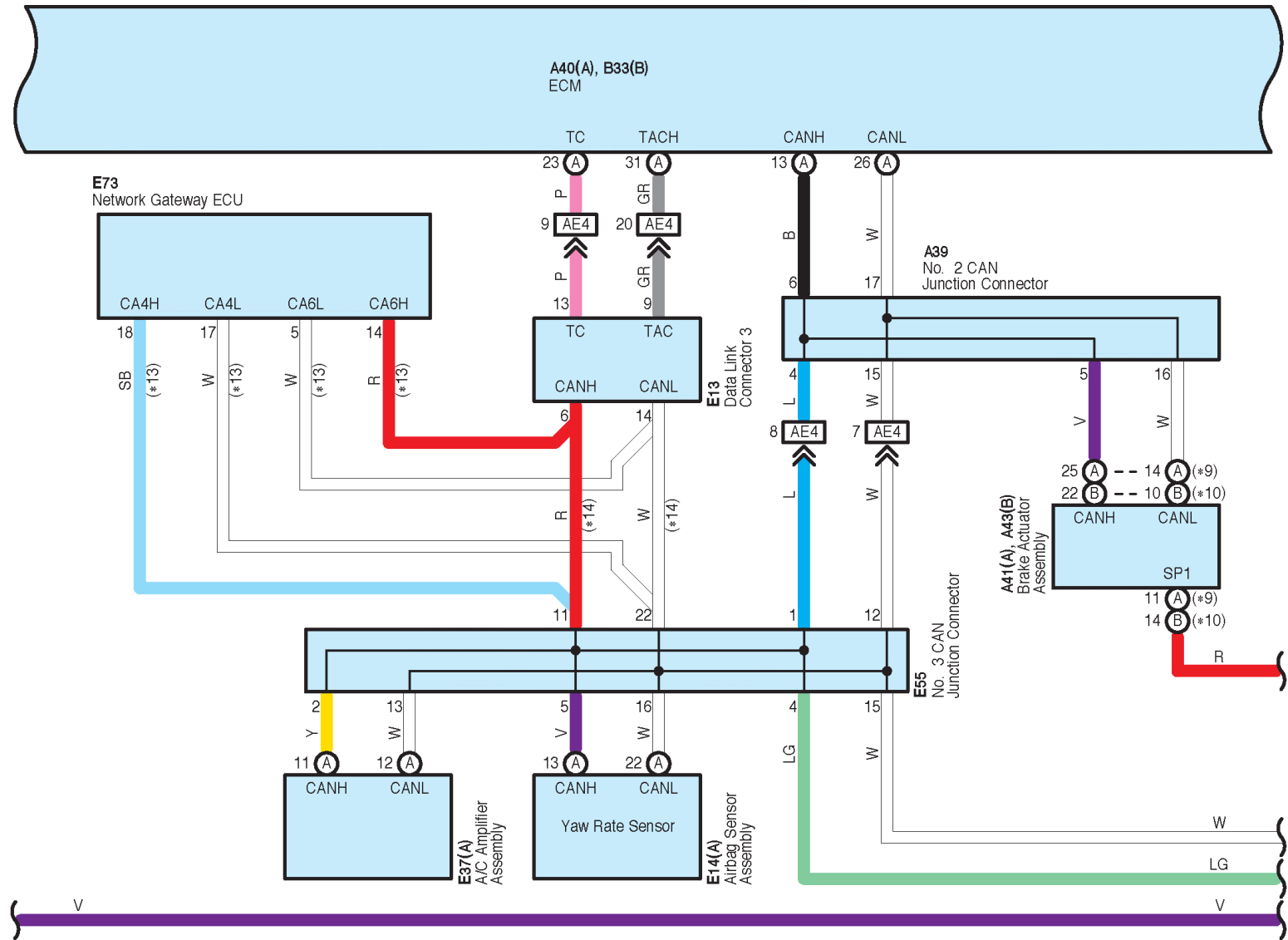

# Cruise Control (2ZR-FAE), CVT and Shift Indicator (2ZR-FAE), Engine Control (2ZR-FAE)

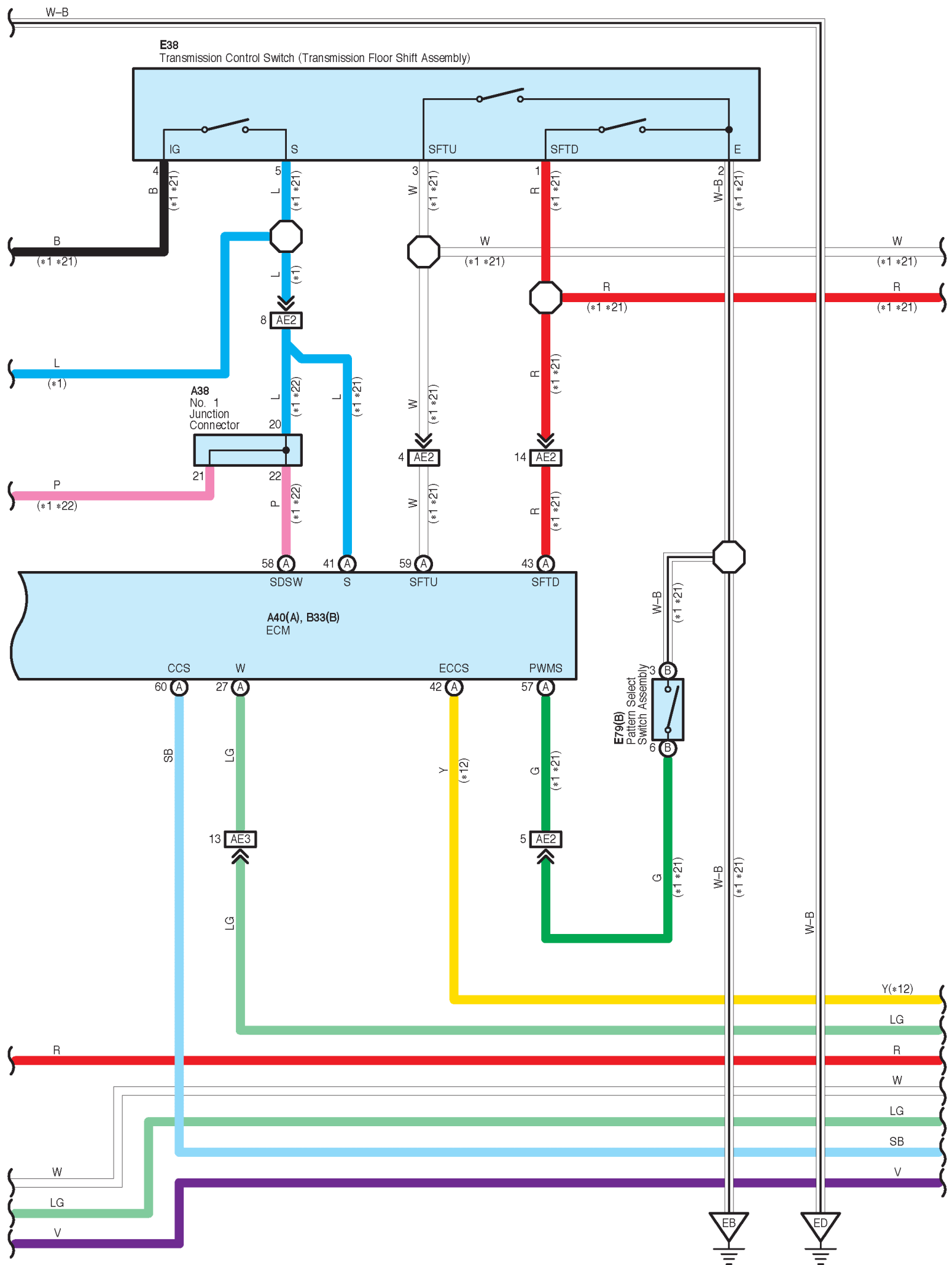

Cruise Control (2ZR-FAE), CVT and Shift Indicator (2ZR-FAE), Engine Control (2ZR-FAE)

- \* 1 : CVT
- \*11 : Before Aug. 2016 Production
- \*12 : From Aug. 2016 Production
- \*13 : w/ Dynamic Radar Cruise Control
- \*14 : w/o Dynamic Radar Cruise Control
- \*21 : w/ Paddle Shift Switch
- \*22 : w/o Paddle Shift Switch

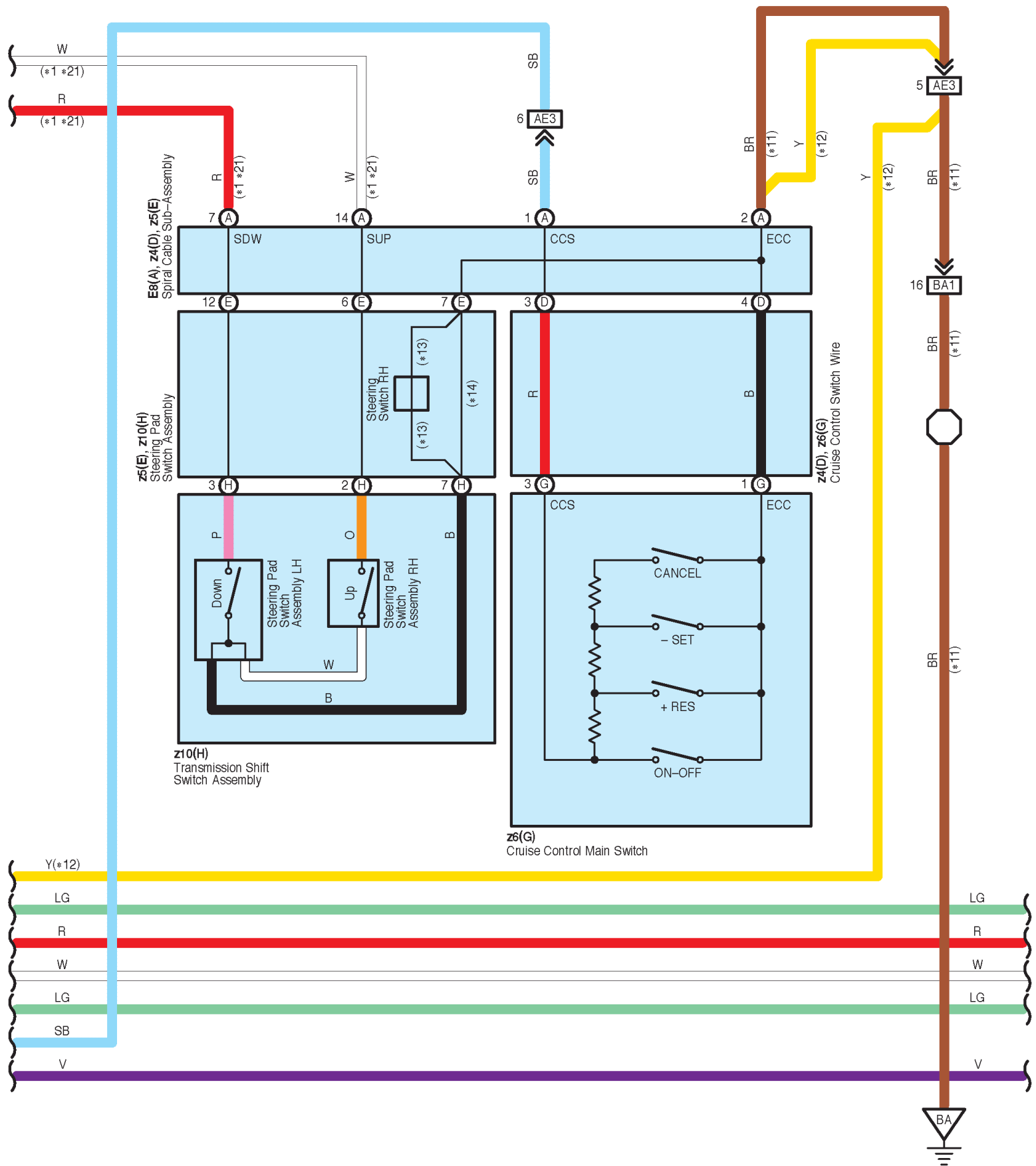

Cruise Control (2ZR-FAE), CVT and Shift Indicator (2ZR-FAE), Engine Control (2ZR-FAE)

- \* 9 : Before Aug. 2015 Production
- \*10 : From Aug. 2015 Production
- \*11 : Before Aug. 2016 Production
- \*12 : From Aug. 2016 Production
- \*13 : w/ Dynamic Radar Cruise Control
- \*14 : w/o Dynamic Radar Cruise Control
- \*19 : LED Type Indicator

